

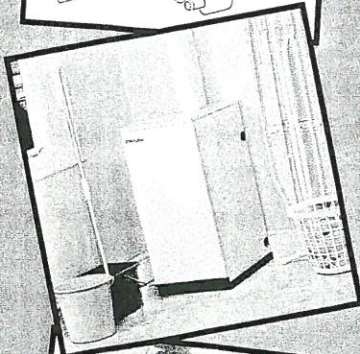

www.hrmboilers.co.uk

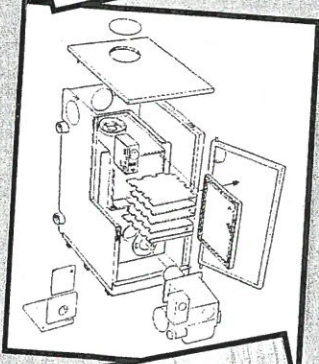
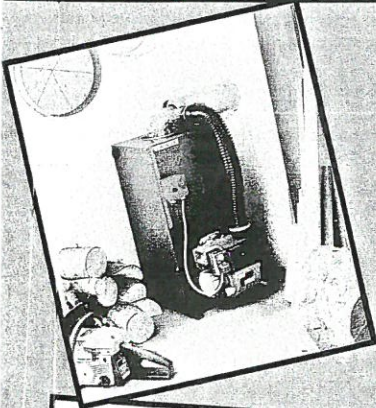
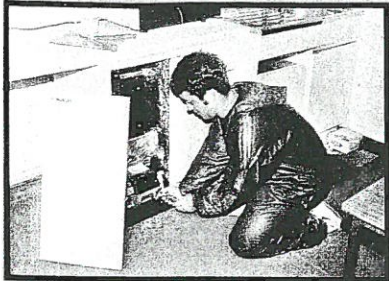

The Simple Solution!

# S H A N D B O O K AND SERVICE LOG

# T

# A

# R

# F

# L

# O

# W

# STARFLOW

by HRM



Your Boiler Serial Number is:

to be found on the Burner Cover

**MODEL**

50/85

85/110



REFRIGERANT R22 R290 R410A

## CONTENTS

	PAGE
HOUSEHOLDER INFORMATION	
- GUARANTEE INFORMATION	3
- GUARANTEE REGISTRATION	INSIDE REAR COVER
- BOILER CONTROLS	4
TECHNICAL	
- BOILER DIMENSIONS	6
- TECHNICAL SPECIFICATIONS	7
- BURNER SETTINGS	7
BOILER INSTALLATION	
- REGULATIONS	8
- BOILER SIZING	8
- REFURBISHING AN OLD SYSTEM	8
- SYSTEM PROTECTION	8
- CONTROL OF DOMESTIC HOT WATER	9
- BOILER LOCATION	9
- ACCESSORIES	9
- FLUE TERMINATING POSITIONS	10
- FUEL SUPPLY SYSTEM	11
- ELECTRICAL CONNECTIONS	12
- FULLY PUMPED Y-PLAN HEATING SYSTEM	13
- CONVENTIONAL FLUE INSTALLATION	14
- BALANCED FLUE INSTALLATION	15
- BALANCED FLUE OPTIONS	16
MAINTENANCE	17
BURNER INFORMATION	
- BURNER HEAD SETTINGS	17
- CONTROL BOX SEQUENCE	18
- PRIMING THE BURNER	18
FAULT FINDING CHART	19
PARTS LIST	
- BURNER	20
- BOILER	21
INSTALLATION AND COMMISSIONING CHECK LIST	22
SERVICE LOG	23
CONTACTS	
- TEL.No. : 01953 455400	
- FAX: 01953 454483	
- E-MAIL : <a href="mailto:sales@hrmboilers.co.uk">sales@hrmboilers.co.uk</a> <a href="mailto:technical@hrmboilers.co.uk">technical@hrmboilers.co.uk</a>	

Dear Householder

Thank you, for selecting a boiler from HRM. Your boiler is the culmination of years of experience in development; testing and manufacture of oil fired equipment.

Our boilers are independently tested and comply with the latest European Boiler Efficiency Directive; our quality assurance procedures are also approved and comply to the International Standard, ISO9000.

Each boiler is manufactured and tested with care by a member of our production team; you will find their name inside the boiler casing.

Your boiler will provide you with a long and trouble free service life provided a few essential steps are addressed. Please take the time to read the "householder information" section of this handbook.

In the unlikely event of a fault, please contact your installer who should be able to identify the cause of the problem, if appropriate your installer will contact us.

*Hedley Mickleburgh*

## HOUSEHOLDER INFORMATION

### IMPORTANT!

Your boiler must be commissioned, in order to:

- Ensure the boiler has been installed correctly and avoid premature failure.
- Set the boiler to its optimum efficiency. Operating conditions for the boiler will vary from site to site, your commissioning engineer has specialised equipment to check the oil pressure and analyse the exhaust gases for "temperature", "smoke" and "CO2" content.
- Your installer will organise commissioning of your boiler; should you experience any difficulty locating an engineer our service department may be able to provide you with the name of an engineer in your area.

### GUARANTEE

Your HRM boiler is guaranteed for 2 years from the date of installation.

#### Guarantee conditions

- The boiler must be installed and commissioned in accordance with our handbook.
- The boiler must not be repaired, modified or tampered with by any person not authorised by HRM.

#### Guarantee exclusions

- The burner nozzle is excluded from guarantee.

### EXTENDED GUARANTEE

#### Help us to help you

The guarantee registration document inside the rear cover should be completed as appropriate by your installer / engineer, this is your record that the boiler has been installed in accordance with our recommendations. Return the copy to HRM in order to qualify for a further 3 years guarantee of the heat exchanger (total **5 years**).

#### Extended guarantee conditions

- The boiler must be serviced annually and maintained in accordance with the handbook, a service log is provided on the back page of this handbook.
- This guarantee is in addition to your statutory and other legal rights.

### AFTER SALES SERVICE

- If your boiler fails during the guarantee period contact your installer, who will be able to identify the cause of the problem, if appropriate, your installer will contact us.
- In no circumstances should "in guarantee" work be undertaken without authorisation from our service department.
- If you are unable to contact your installer please contact our service department.

## BOILER CONTROLS

### Control panel

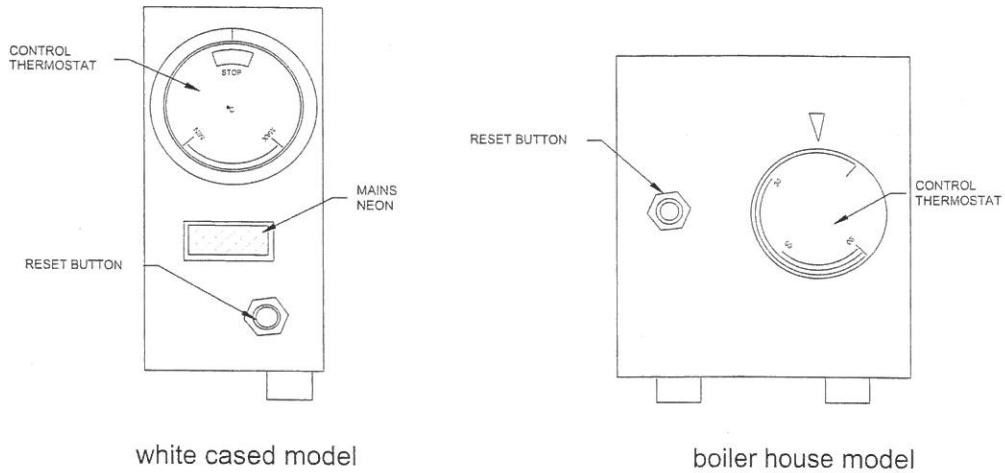

### Temperature control thermostat

The control thermostat regulates the temperature of the water within the boiler.

The recommended settings are "MAX." for heating and hot water and "MIN." for hot water only.

Do not operate the boiler below the minimum setting; this will induce corrosion and reduce the life of the boiler.

### Boiler overheat (limit) thermostat

If the boiler overheats the reset button will trip and cut the power supply to the boiler, allow the boiler to cool then press the reset button to reset the thermostat.

**IMPORTANT** – if overheating occurs, other than very occasionally, consult your installation engineer there may be a fault with the central heating system.

### Mains neon lamp (white cased model only).

The lamp is illuminated when there is power to the control thermostat and the control system (time clock) is calling for heat

NOTE - The lamp will not be illuminated if the overheat (limit) thermostat has tripped.

## Burner reset button

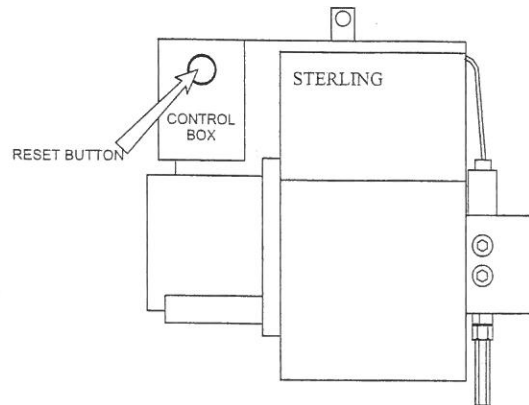

The burner is equipped with a flame failure device, when activated the reset button on the burner control box is illuminated. Refer to the fault finding section of the handbook to identify possible causes.

## Switching the boiler on

- turn on the oil supply
- switch on the mains supply
- set the timer control to on
- set the boiler control thermostat to the required setting

## Switching the boiler off for long periods

- have the boiler serviced
- switch off the mains supply
- turn off the oil at the tank

## Oil delivery

Switch the boiler off during an oil delivery, wait for a short period before switching the boiler on to allow sediment in the bottom of the tank to settle.

## Maintenance

Your boiler should be serviced annually, failure to have this done will invalidate your guarantee and also lead to inconvenient breakdowns. A service log is provided on the back page of the handbook.

If you have difficulty in locating a service engineer please contact our service department who may be able to provide you with the name of an engineer in your area.

TECHNICAL INFORMATION

BOILER DIMENSIONS

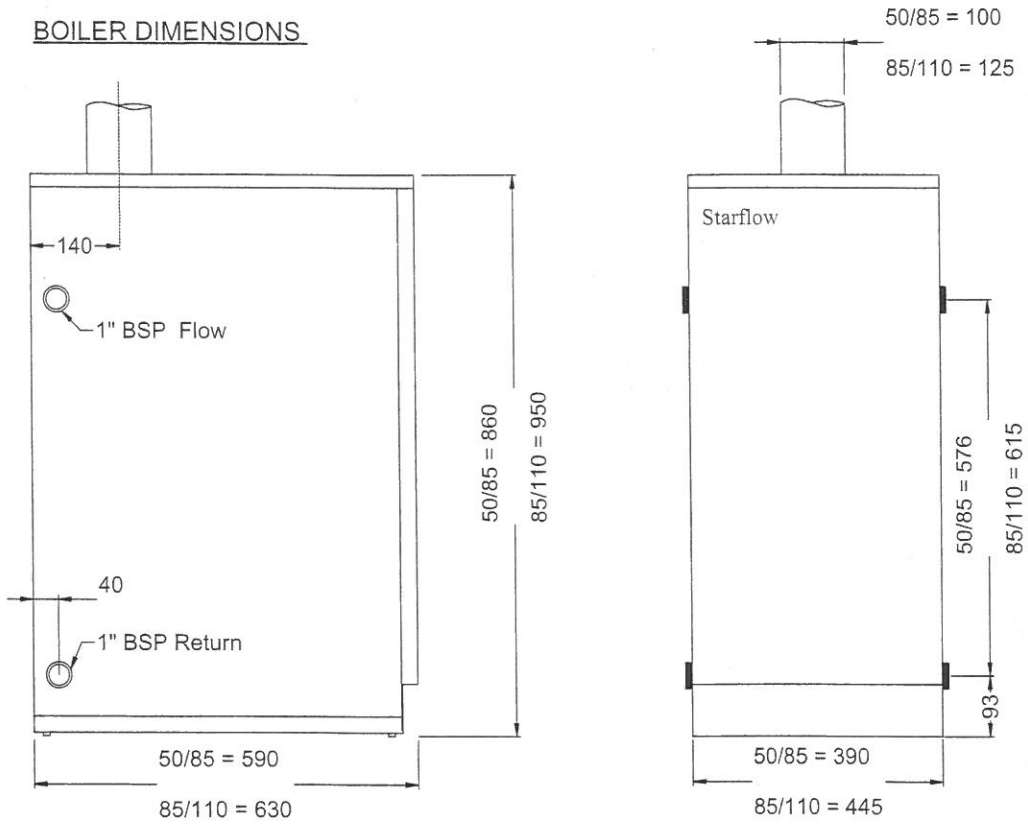

DIMENSIONS WHITE CASED MODEL

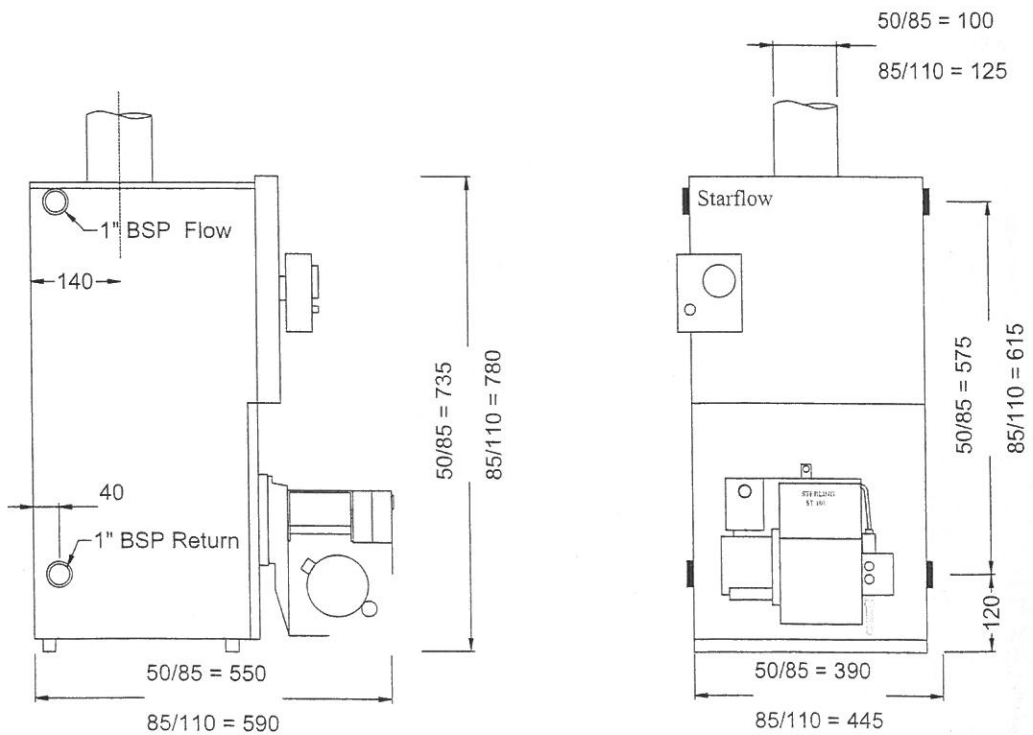

DIMENSIONS BOILER HOUSE MODEL

## TECHNICAL SPECIFICATIONS

Heating system requirements:	conventional open vented or sealed systems.
Maximum operating pressure:	3bar (43.5psi) static head 30 meters (100 feet)
Operating Temperature:	60°C to 80°C Maximum
Resistance to water flow:	@ 10°C temperature rise across the boiler model 50/85 = 32 mm W.G. 85/110 = 68mm W.G.
Conventional flue draught limit:	Min. 12.5 Nm <sup>2</sup> (0.05" W.G.) Max. 33.0 Nm <sup>2</sup> (0.13" W.G.)
Thermostats:	control thermostat range = 58-88 degrees C limit thermostat, manual reset , set point = 110-6 degrees C
Electrical supply:	230v single phase 50Hz, fused 5 amp
Burner:	Sterling 40 - 50/85, Sterling 50 – 85/110
Fuel:	kerosene 28 second class C.
Oil supply connection:	¼" BSP
Weight empty:	50/85 = 88kg, 85/110 = 90kg
Water capacity:	50/85 = 16.5 litres, 85/110 = 20 litres

## BURNER SETTINGS

BOILER MODEL		50/85			85/110		
OUTPUT	Btu/h x	50	65	80	85	92	104
	k/W	15	19	23	25	27	30
Nozzle	US/GPH Size &Type	0.5 80.0 EH	0.65 80.0 EH	0.75 80.0 EH	0.85 80.0 EH	0.85 80.0 EH	1.0 80.0 EH
Oil Pressure	BAR	7.5	7.0	7.5	7.0	9.0	8.0
	PSI	110	100	110	100	130	115
Firing Rate	Kg/hr	1.45	1.81	2.17	2.31	2.48	2.69
	Litres/hr	1.84	2.29	2.75	2.92	3.14	3.41
Air Setting	SCALE	4.5	7.5	10.5	7.0	10.0	13
Smoke	Bacharach Scale	0	0	0	0	0	0
Co <sub>2</sub>	%	10.5	11.0	11.5	12	12	12
Flue Gas Temp.	Less Ambient °C	210	220	230	235	245	255

Note. Burners are factory set at mid range.



## BOILER INSTALLATION

### REGULATIONS

The installation of oil fired boilers must comply with the following Standards and Codes of Practice.

BS 5410 – Part 1	Oil installations up to 45kw
BS 5449	Forced circulation hot water central heating systems for domestic premises
BS 4543 – Part 1 & 3	Factory made insulated chimneys.
BS 7593:1992	Treatment of water in hot water central heating systems
Building Regulations	Part J England and Wales, Part F Scottish Regulations and Technical Booklet L Northern Island
BS7671: 1992	Electrical Regulations

### BOILER SIZING

It is important to establish the correct size of boiler required, boiler output will depend on a number of factors including:

- the preferred room temperatures
- the design winter temperature
- structural and ventilation heat losses
- domestic hot water requirements

This is a complicated calculation, we recommend you employ the services of a heating engineer, who will determine the correct size of boiler required for your property.

### REFURBISHING AN OLD SYSTEM

#### **WARNING! – BEFORE INSTALLING A NEW BOILER**

The system should be chemically cleaned to remove debris in the form of black magnetite sludge and lime scale that accumulates in radiators and pipe work. Failure to do this will result in debris adhering to the clean surfaces of a new boiler, causing kettling or knocking noises it also prohibits efficient heat transfer. A cleanser such as Fernox Superfloc can be added to the system 48hrs prior to changing the boiler.

### SYSTEM PROTECTION

#### After installation

Flush the system with a cleanser such as Fernox Superfloc to remove traces of flux residues, grease, metal swarf, solder pieces and oils used during component manufacture.

#### After flushing

Add a corrosion inhibitor such as Fernox MB-1, this will minimise the chemical action and chemical changes that takes place in the system primary water and system components.

#### Note.

The manufacturer's usage instructions for chemical cleaners and inhibitors should always be followed. Please refer to BS7593 for a detailed explanation of cleansing procedures.

## CONTROL OF DOMESTIC HOT WATER

In many older systems the domestic hot water is heated by gravity circulating. Reduced running costs can be achieved by converting to a fully pumped system with the benefit of controlled hot water temperature and reduced short cycling of the boiler.

## BOILER LOCATION

Noise levels - consideration should be given to the following:

- some people are sensitive to even low noise levels.
- conventional chimneys create more noise than balanced flues
- small rooms will accentuate noise levels
- where a flue terminates near the boundary of an adjoining property, consideration should be given to possible noise disturbance as some people are sensitive to even low noise levels.

Installation within bathrooms is not permitted

A balanced flue must be used for garage installations

Roof space and bedroom installation should only be considered where there is no alternative.

To provide access for maintenance allow at least 700mm in front of the boiler.

## THE HEARTH

A non-combustible hearth should be provided for the boiler.

## ACCESSORIES

Remote acting fire valves	1.5m capillary 66'deg.	Pt. No. BS1.5
	3.0m capillary 66'deg.	Pt. No. BS3
	6.0m capillary 66'deg.	Pt. No. BS6
	9.0m capillary 66'deg.	Pt. No. BS9
	15.0m capillary 66'deg.	Pt. No. BS15
Non-return valve	3/8" BSP	Pt.No. BS008
Oil filter	¼" BSP paper element type	Pt. No. BS072
Stainless steel flue guard	11" x 11" x 10.5"	Pt. No. 50/110FG
Balanced flue extension kits – horizontal		
	50/85 x 150mm	Pt. No.50/85HE15
	50/85 x 300mm	Pt. No.50/85HE3
	85/110 x 150mm	Pt. No.85/110HE15
	85/110 x 300mm	Pt. No.85/110HE3
Balanced flue extension kits - vertical		
	50/85 x 300mm	Pt. No. 50/85VE3
	50/85 x 600mm	Pt. No. 50/85VE6
	50/85 x 900mm	Pt. No. 50/85VE9
	85/110 x 300mm	Pt. No. 85/110VE3
	85/110 x 600mm	Pt. No. 85/110VE6
	85/110 x 900mm	Pt. No. 85/110VE9

## FLUE TERMINATING POSITIONS

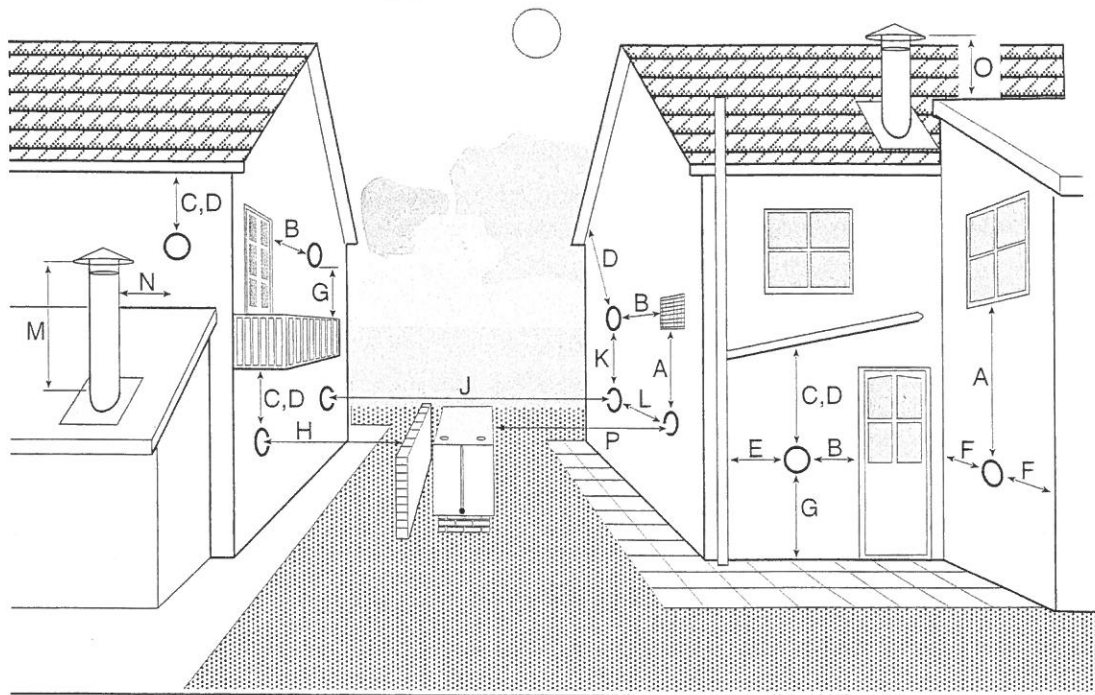

A	Directly below an opening. (air brick, window, etc.)	600
B	Horizontally to an opening. (air brick, window, door, etc.)	600
C	Below a gutter, eaves or balcony with protection (note 2)	75
D	Below a gutter, eaves or balcony without protection	600
E	From vertical sanitary pipework	300
F	From an internal or external corner	300
G	Above ground or balcony level	300
H	From a surface or boundary facing the terminal	600
J	From a terminal facing a terminal	1200
K	Vertical from a terminal on the same wall	1500
L	Horizontally from a terminal on the same wall	750
M	Above the highest point of an intersection with the roof	600
N	A vertical surface from the side of the terminal	750
O	Above a vertical structure less than 750mm from the side of the terminal	600
P	From an oil tank	1800

Information from BS5410:Part 1:1997

Note 1. Terminals should be positioned so as to avoid products of combustion accumulating in stagnant pockets around the building or entering into buildings.

Note 2 Where a flue is terminated less than 600mm away from a projection above it and the projection consists of plastics or has a combustible or painted surface, then a shield of at least 750mm should be fitted to protect these surfaces.

Note 3 If the lowest part of the terminal is less than 2m above the ground, balcony, flat roof or other place to which any person has access, the terminal should be protected by a guard.

Note 4 Where a flue terminates near the boundary of an adjoining property, consideration should be given to possible noise disturbance, as some people are sensitive to even low noise levels.

## FUEL SUPPLY SYSTEM

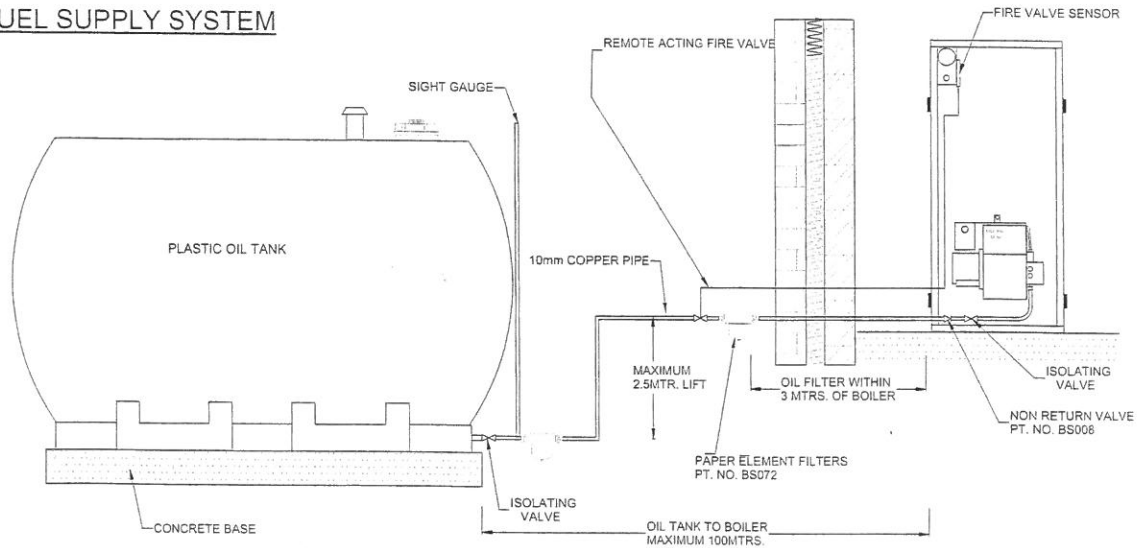

### Oil tank

We recommend the use of plastic oil tanks, they require less maintenance than steel tanks and are longer lasting.

A concrete base 100mm thick is sufficient support for the tank, alternatively use paving slabs of 42mm thickness on a suitable layer of compacted hard core. Ensure enough clearance is provided to allow removal of the oil filter bowl.

### Oil supply

#### Fuel tank below the burner

The fuel pump can lift fuel to a height of 2.5 metres, A two pipe system or a deaerator (Tiger loop, 3 K or similar) is not required. For heights above 2.5 metres, please consult our technical department.

A non-return valve must be fitted near the boiler. ( $\frac{3}{8}$ " NRV - Pt. No. BS008)

### Pipework

Soldered fittings should not be used, the joints will fail in the event of fire, flux deposits may damage the pump also fuel may deteriorate the solder within the joint.

Galvanised pipe and fittings must not be used, the aggressive action of the fuel will erode the zinc and damage the fuel pump.

Keep the number of pipe joints to a minimum, form bends rather than use compression fittings.

### Jointing compounds

Jointing compounds should be used with care, excessive amounts can causing blockages, fragments may cause failure of the fuel pump or the non-return-valve; we recommend the use of a non-setting liquid pipe sealant.

### Fire valve

A remote acting fire valve must be installed, please refer to the accessories section for details of our range.

### Oil filtration

A paper element filter must be installed within 3 meters of the boiler ( $\frac{1}{4}$ " filter Pt. No. BS072). Paper element filters have high filtration rates (12 microns), gauze strainers, which are commonly used, have a filtration rate of 100 microns they do not provide the best protection for the highly tolerated components within the burner, and may lead to the premature failure of burner components. Where a steel oil tank is installed we recommend a paper element filter is also fitted adjacent to the oil tank.

## ELECTRICAL CONNECTIONS

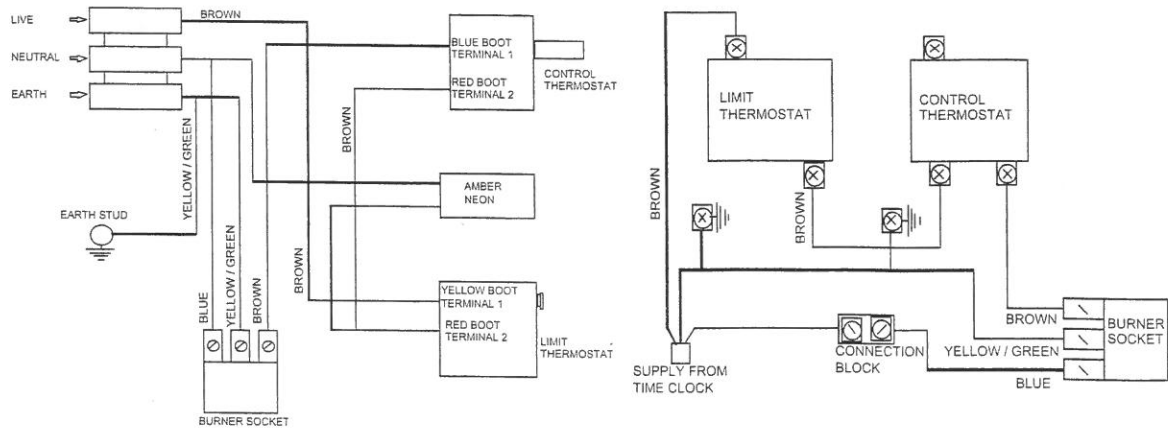

White cased model

Boilerhouse model

The electrical supply to the boiler should be made via a switched and fused spur located near the boiler, fitted with a 5-amp fuse.

A frost thermostat may be required where the boiler is installed in an outbuilding.

## HONEYWELL Y-PLAN FULLY PUMPED SYSTEM

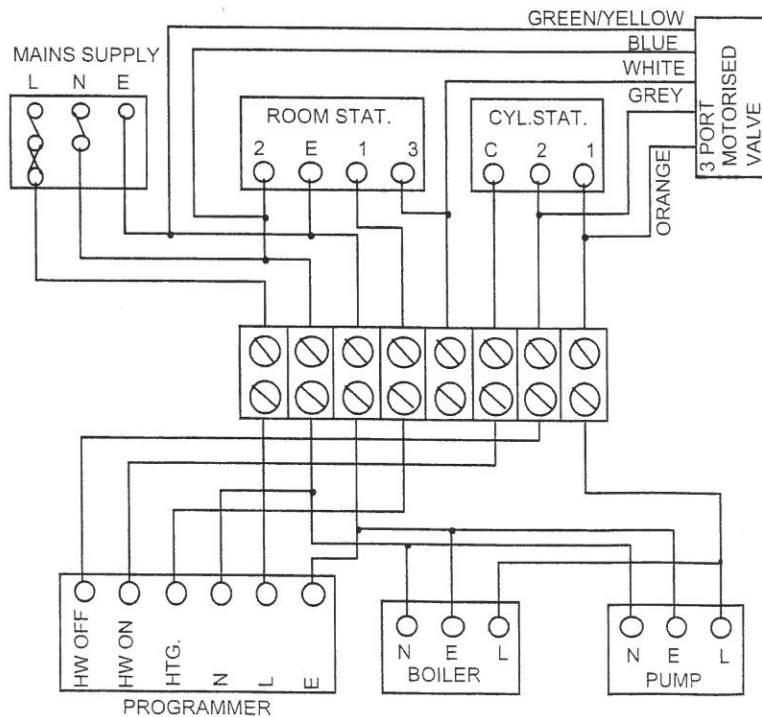

## FULLY PUMPED Y-PLAN HEATING SYSTEM

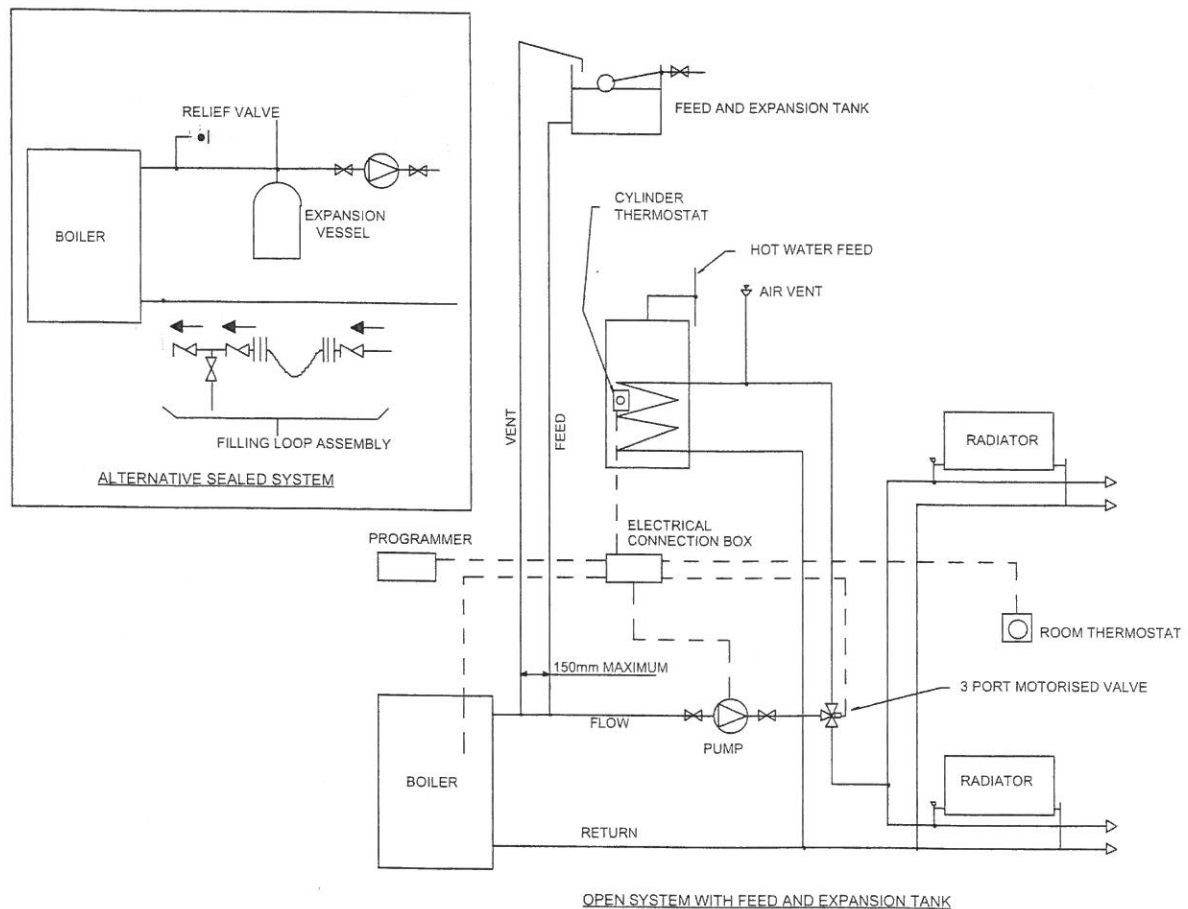

Diagram shows a general arrangement only, there are many alternative systems. Sealed system components are available in the form of a kit from your plumber's merchant.

## CONVENTIONAL FLUE INSTALLATION

The boiler is supplied for use with conventional flue.

Where an existing chimney is being used it should be fitted with a flexible or rigid stainless steel liner, back filling with a suitable insulation material may be necessary to avoid condensation. The risk of condensation increases if the flue gas temperature falls below 60°C measured 0.5 mtrs. from the top of the chimney.

To comply with building regulations a sample point must be provided in the flue pipe within 450mm from the top of the boiler.

A draught stabiliser may be required for chimneys over 6 meters in height as they may produce excessive draught, see technical details.

A conventional flue is unsuitable for garage installation, where petrol could be stored in cans or vehicles.

An air supply is required for combustion of fuel and also ventilation for the boiler. Position extraction fans and tumble dryers as far as possible away from the boiler. A combustion test must be carried out with these appliances operating, with all doors and windows closed, to ensure there is no interference with the performance of the boiler.

CONVENTIONAL FLUE AIR REQUIREMENTS

BOILER IN A ROOM

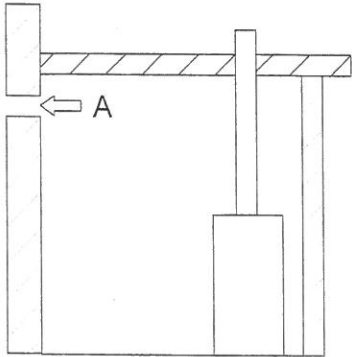

BOILER IN A CUPBOARD  
VENTILATED FROM OUTSIDE

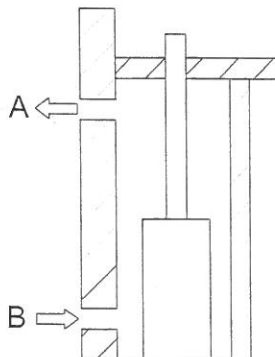

BOILER IN A CUPBOARD  
VENTILATED FROM A ROOM

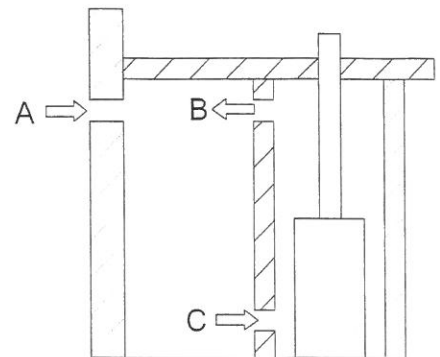

FREE AREA OF VENTILATION GRILL CM<sup>2</sup>

MODEL	A	B	C
50/85	130	260	390
85/110	160	320	480

CONVENTIONAL FLUE, GENERAL ARRANGEMENT

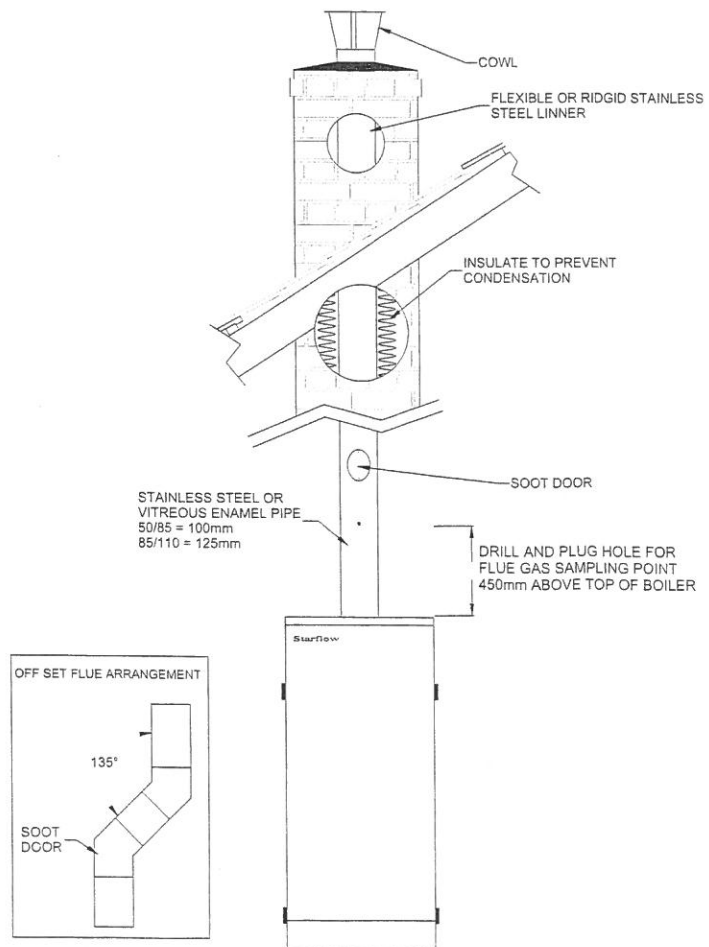

## BALANCED FLUE INSTALLATION

### Horizontal flues

The flue is telescopic, as supplied the flue has a range of 220mm – 350mm from the rear of the boiler, extension kits of 150mm and 300mm are available. The maximum extension length is 950mm.

In side outlet mode, allow 100mm clearance between the side of the boiler and the internal face of the wall, the telescopic range of the flue is reduced by 155mm for Model 50/85 and 180mm for Model 85/110.

If the lowest part of a terminal is less than 2000mm above the ground, or other place to which any person has access, a terminal guard must be fitted.

### Vertical flues

The flue is telescopic, as supplied the flue has a range of 2000mm - 2600mm from floor level to the top of the flue, extension kits of 300mm, 600mm and 900mm are available. The maximum extension length is 5 metres.

### Ventilation air supply

Air for ventilation is required if the boiler is installed in a confined space, i.e. a cupboard, to prevent overheating of components and any equipment nearby.

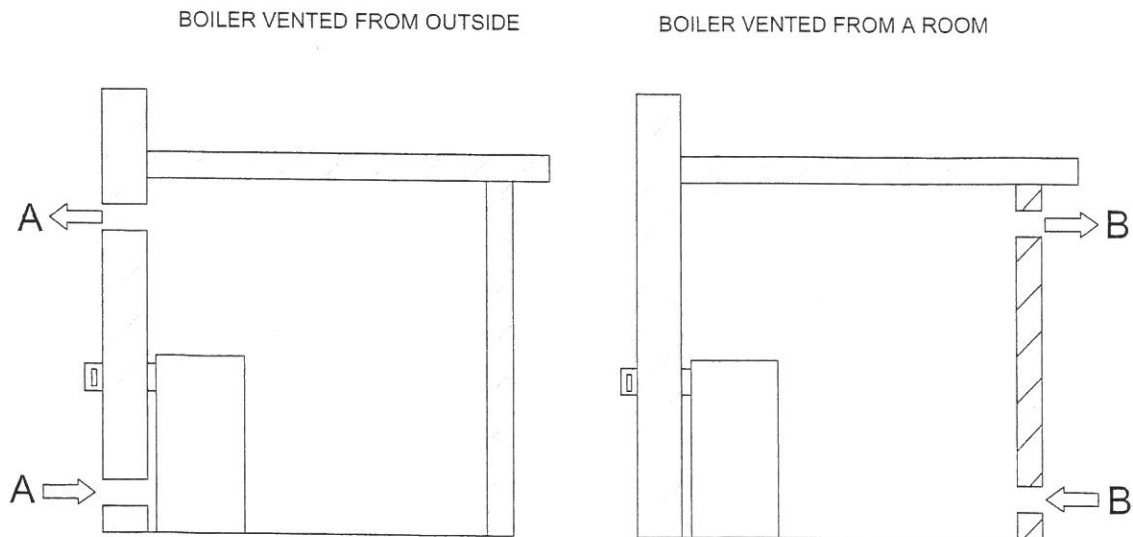

### FREE AREA OF VENTILATION GRILL CM<sup>2</sup>

MODEL	A	B
50/85	130	260
85/110	160	320



**BALANCED FLUE OPTIONS**

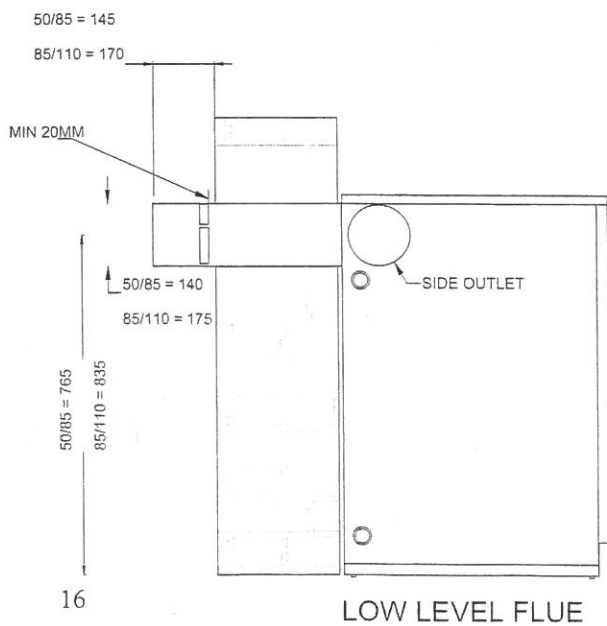
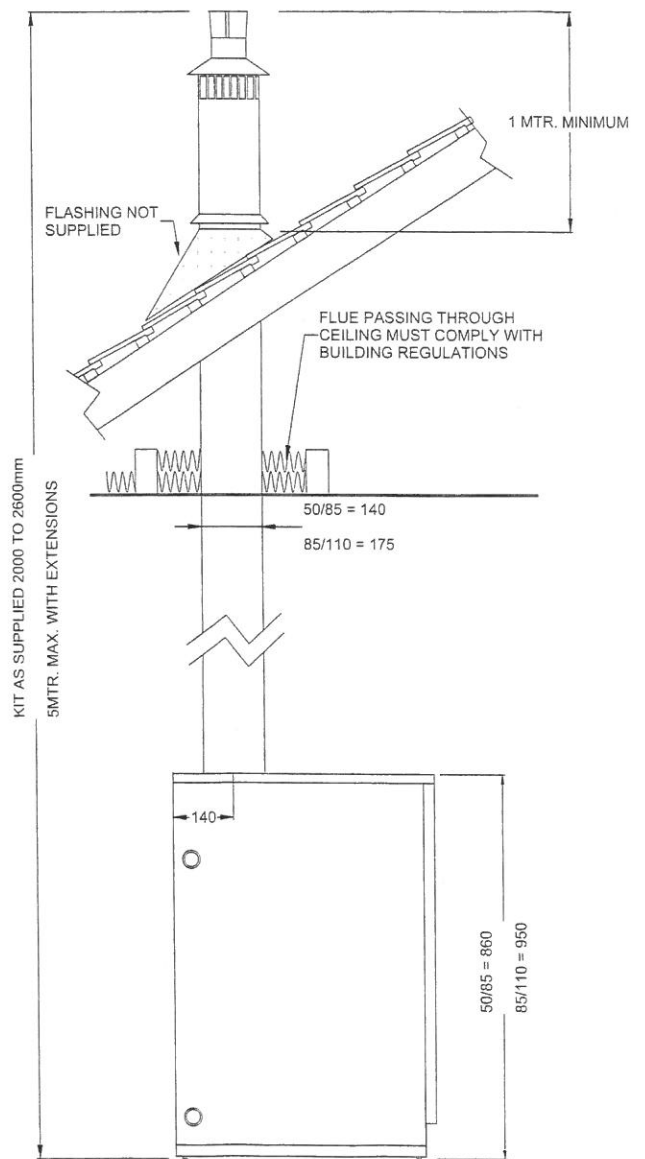
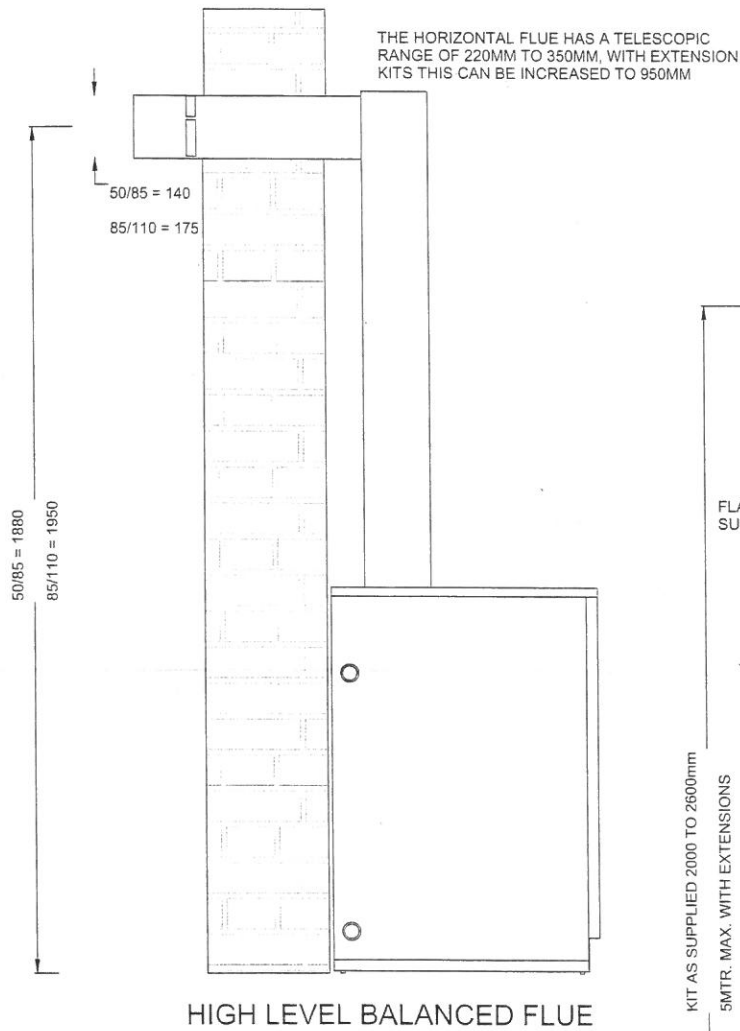

## MAINTENANCE

The boiler should be serviced annually. Should you experience any difficulty in locating an engineer our service department may be able to provide you with the name of an engineer in your area.

### **WARNING!** ISOLATE THE POWER SUPPLY BEFORE SERVICING THE BOILER

1. Remove the burner and combustion chamber baffles, clean the internal heat exchanger surfaces and components.
2. Check and replace seals and gaskets as appropriate.
3. Clean / replace filter elements and desludge the oil tank.
4. Dismantle the burner assembly and clean, fit a new nozzle.
5. Check the oil pressure and flue gas analysis, adjust the burner settings as appropriate.

## BURNER HEAD SETTINGS

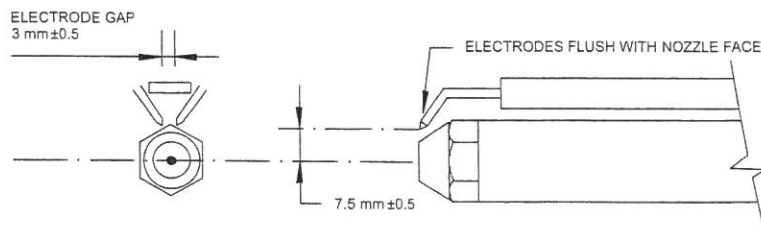
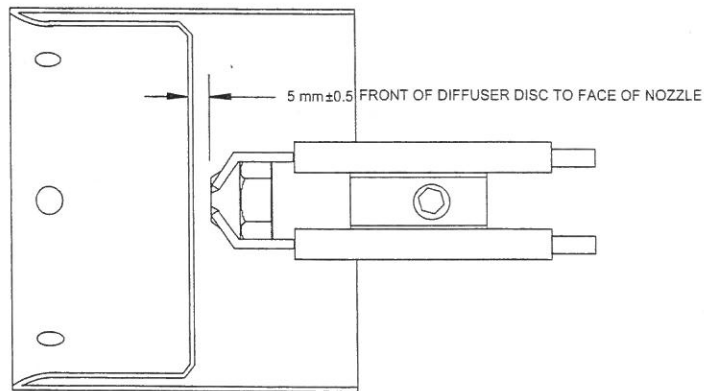

## DISMANTLE THE BURNER

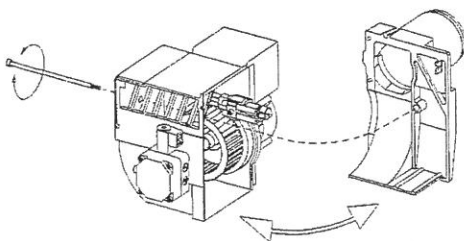

## AIR ADJUSTMENT

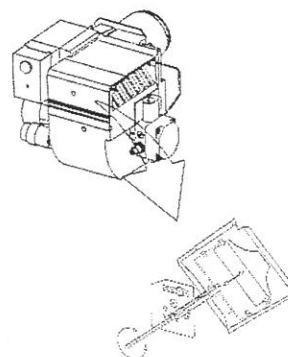

## CONTROL BOX PROGRAMME SEQUENCE FOR THE SATRONIC TF 832.3

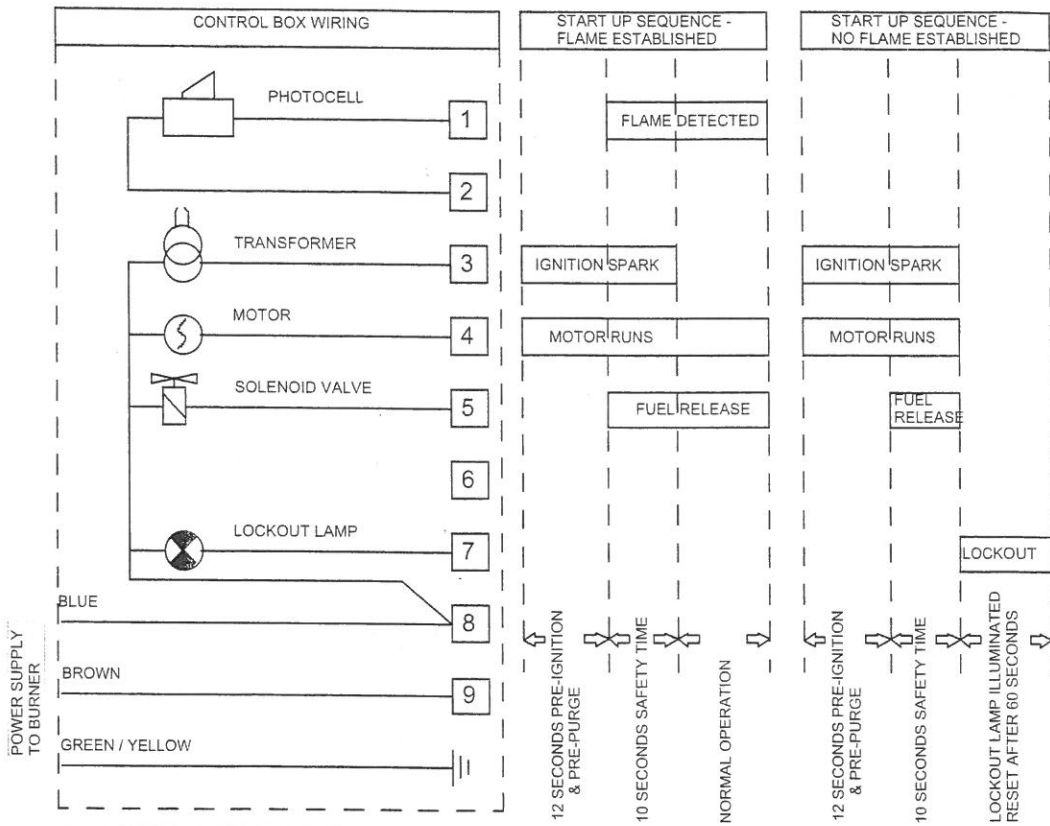

NOTE:

SAFETY TIME, IF A FLAME IS NOT ESTABLISHED BEFORE THIS TIME LIMIT THE CONTROL BOX WILL GO TO LOCKOUT, IF THE FLAME IS EXTINGUISHED AFTER THIS PERIOD, THE BURNER WILL MAKE AN ATTEMPT TO RE-START.

### PRIMING THE BURNER

Ensure both power and fuel supplies to the boiler are switched on. Press the reset button, the burner will start its firing sequence, to release air from the oil line slacken the vent plug during this period. If ignition fails the burner will go to lockout, wait 60 seconds and repeat the procedure.

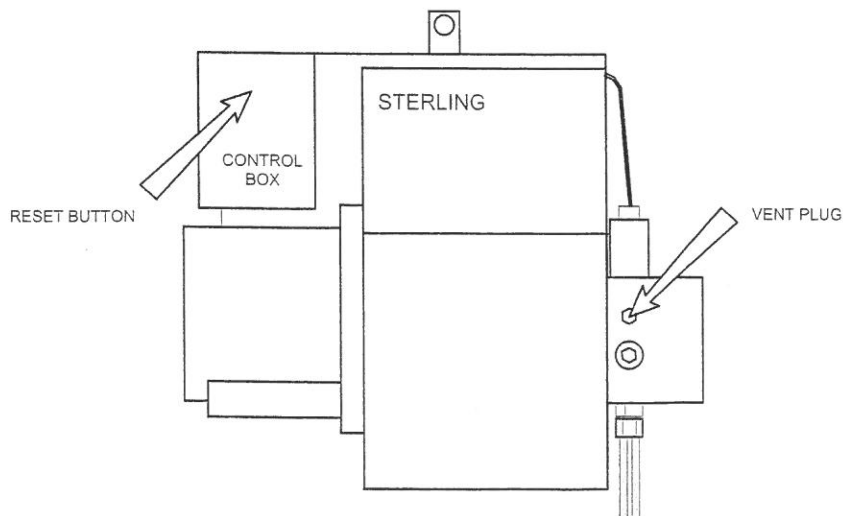

## FAULT DIAGNOSIS

Burner fails to start → Mains lamp not illuminated

- blown fuse
- time clock / programmer not calling for heat
- room or hot water thermostats not calling for heat

Burner lock out lamp is illuminated → flame extinguishes after a short period

- photocell faulty
- faulty control box

→ no spark

- faulty control box
- faulty ignition transformer
- incorrect electrode setting
- faulty HT leads

→ lack of oil

- faulty solenoid coil
- blocked nozzle / jet
- faulty fire valve
- air in oil supply
- empty oil tank

Motor does not run →

- seized oil pump
- motor faulty
- control box faulty
- capacitor faulty

Radio / T.V interference →

- incorrect electrode setting
- poor earth bonding
- faulty ignition transformer

Smoky exhaust →

- blocked nozzle / jet
- incorrect burner settings

Burner starts violently → delayed ignition

- incorrect electrode adjustment
- electronic insulation damaged
- HT leads faulty
- air in oil supply
- incorrect air adjustment

Oil odours →

- incorrect combustion settings
- oil leak

Unstable flame →

- incorrect head settings
- low oil pressure
- excess air
- excessive flue draught
- faulty nozzle

PARTS LISTS - STERLING BURNER

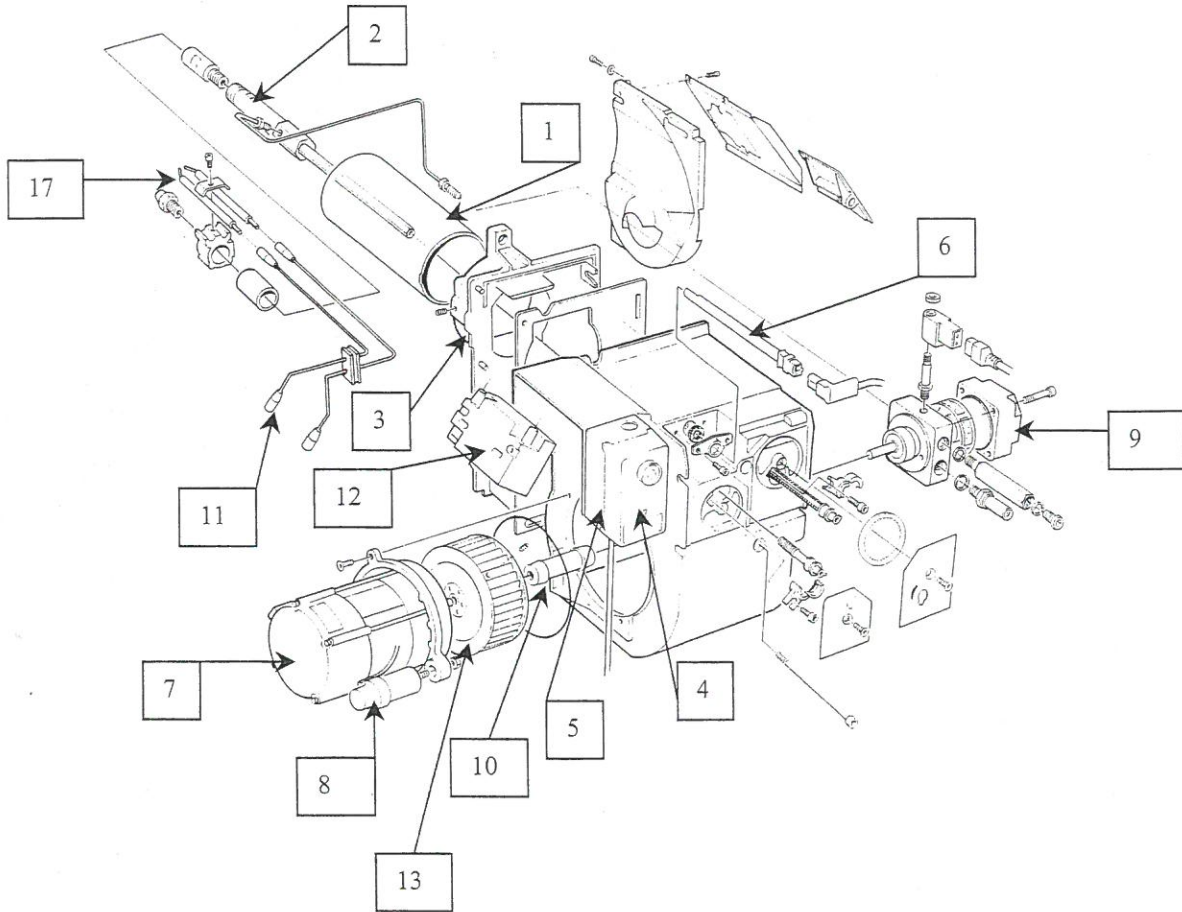

ITEM	DESCRIPTION	EOGB REF.	PART No.
1	Blast Tube 50/85	B03-177-80105	BS058
1	Blast Tube 85/110	B03-177-80103	BS059
2	Nozzle Assembly	118-538-01	BS046
3	Intermediate Gasket	04-390-120-27	BS047
4	Satronic Control Box	TF832.3	BS021
5	Control Box Base	390-109-01	BS022
6	Photocell MZ770S	118-003-01	BS065
7	Motor	118-483-02	BS050
8	Capacitor	118-952-01	BS051
9	Danfoss Pump BFP11 L3	117-586-02	BS052
10	Pump Coupling	CO-1-00-115-94201	BS064
11	HT Lead	115-978-03	BS054
12	Transformer EB1	115-977-01	BS055
13	Fan 85/110	114-176-01	BS061
14	Fan 50/85	114-176-04	BS056
15	Flexible oil line (not shown)		BS057
17	Ignition electrode (one piece)	118-867-01	BS067

PARTS LIST

WHITE CASED MODEL

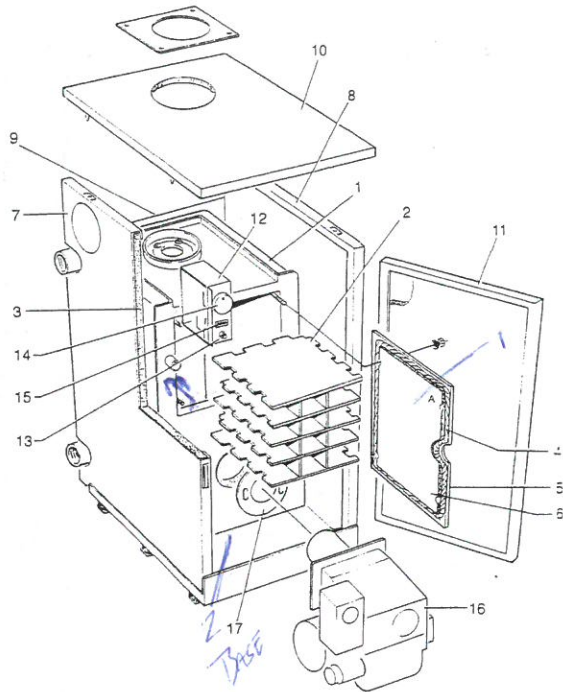

BOILERHOUSE MODEL

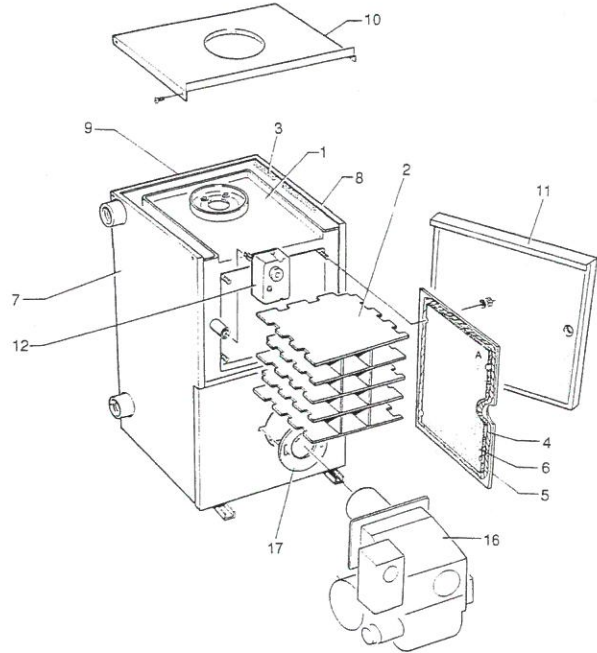

ITEM	DESCRIPTION	50/85	85/110	50/85BH	85/110BH
1	Heat exchanger	SH5001	SH8001	SH5001	SH8001
2	Baffle set	SH5002	SH8002	SH5002	SH8002
3	Fibreglass insulation set	SI5001	SI8001	SI5001	SI8001
4	Glass rope – door seal	IN003	IN003	IN003	IN003
5	Access door	SH5003	SH8003	SH5003	SH8003
6	Ceramic insulation set	SI5002	SI8002	SI5002	SI8002
7	L.H. side panel	SP5001	SP8001	SG5001	SG8001
8	R.H. side panel	SP5002	SP8002	SG5002	SG8002
9	Back panel	SP5003	SP8003	SG5003	SG8003
10	Top panel	SP5004	SP8004	SG5004	SG8004
11	Front casing	SP5005	SP8005	SG5005	SG8005
12	Control panel	SE5001	SE5001	SE5002	SE5002
13	High limit thermostat	EL019	EL019	-	-
14	Control thermostat	EL005	EL005	-	-
15	Red neon	EL004	EL004	-	-
16	Burner assembly	SB5001	SB8001	SB5001	SB8001
17	Burner flange gasket	BS049	BS049	BS049	BS049

INSTALLATION AND COMMISSIONING CHECK LIST

IMPORTANT: Your guarantee will become null and void if your boiler is not commissioned.

OIL SUPPLY

- Is the tank supported on a suitable base? \_\_\_\_\_
- Is an oil level gauge fitted? \_\_\_\_\_
- Are stop valves fitted, adjacent to the oil tank and the boiler? \_\_\_\_\_
- Are filters fitted, adjacent to the oil tank and the boiler? \_\_\_\_\_
- Is at least one of the filters of the paper element type? \_\_\_\_\_
- Is a remote acting fire valve fitted? \_\_\_\_\_
- Check that no soldered fittings have been used \_\_\_\_\_
- Check that no galvanised fittings have been used \_\_\_\_\_

ELECTRICAL

- Is there a double pole isolation switch adjacent to the boiler? \_\_\_\_\_
- Is a 5-amp fuse fitted to the power supply? \_\_\_\_\_

BOILER

- Are the thermostat phials in their pockets? \_\_\_\_\_
- Are the heat exchanger baffles in position? \_\_\_\_\_

WATER

- Has the system been flushed with a chemical cleaner? \_\_\_\_\_
- Has a corrosion inhibitor been added to the system? \_\_\_\_\_

CONVENTIONAL FLUE

- Has a test point been provided? \_\_\_\_\_
- Is the air supply for combustion adequate? \_\_\_\_\_

BALANCED FLUE

- Have all joints been made good? \_\_\_\_\_
- Are the air intake ducts unobstructed? \_\_\_\_\_
- Is a flue terminal guard fitted? \_\_\_\_\_

COMBUSTION TEST RESULTS

Oil pressure = \_\_\_\_\_ Smoke no. = \_\_\_\_\_ CO<sup>2</sup> % = \_\_\_\_\_ Flue gas temperature = \_\_\_\_\_

HANDING OVER TO THE HOUSEHOLDER

- Explain the boiler controls, refer to pages 4 and 5. \_\_\_\_\_
- Explain the operation and setting of the programmer or time switch. \_\_\_\_\_
- Explain the operation of the oil level gauge. \_\_\_\_\_
- Complete the guarantee document inserted in the rear cover and leave the handbook with the householder. \_\_\_\_\_

COMMISSIONED BY: ..... Date.....





HRM Boilers  
Haverscroft Industrial Estate  
Attleborough  
Norfolk  
NR17 1YE

Tel.: 01953 455400  
Fax: 01953 454483

Web site: [www.hrmboilers.co.uk](http://www.hrmboilers.co.uk)

E-mail: [sales@hrmboilers.co.uk](mailto:sales@hrmboilers.co.uk) [technical@hrmboilers.co.uk](mailto:technical@hrmboilers.co.uk)

Part no LI002 Issue 9





**[www.hrmboilers.co.uk](http://www.hrmboilers.co.uk)**

Haverscroft Industrial Estate  
Attleborough Norfolk NR17 1YE  
Telephone: 01953 455400 Fax: 454483

E-mail: [sales@hrmboilers.co.uk](mailto:sales@hrmboilers.co.uk)  
E-mail: [technical@hrmboilers.co.uk](mailto:technical@hrmboilers.co.uk)